

SENATOR™ G2 275 & 300



4000 - 4350
PSI

20 - 21
L/PM

HONDA GX630
PETROL
ENGINE TYPE
POWERED by HONDA.

GEARBOX
1450RPM
DRIVE

COLD WATER
OUTPUT

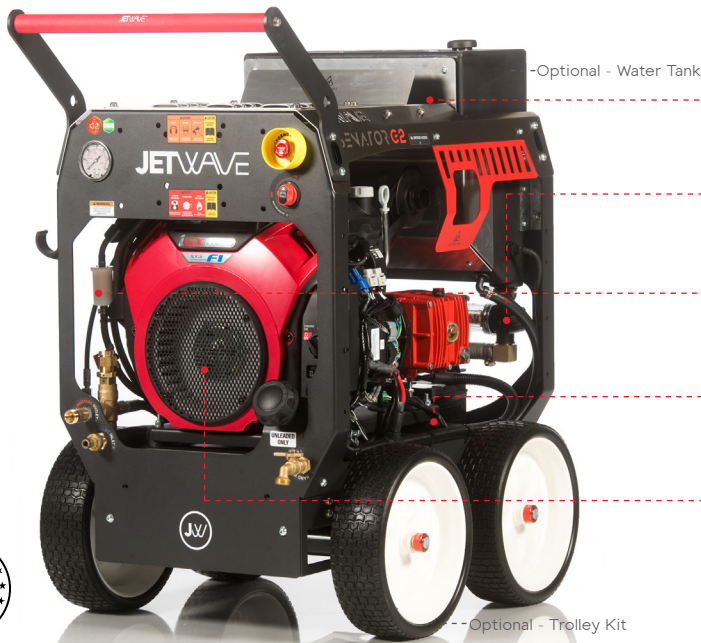

HERO INNOVATIONS



PEXO™
Stainless Steel Exoskeleton



JWPP™
Jetwave Italian Premium Pump



CC™
Centralised Control



AVPS™
Anti Vibration Protection System



MC™
Multi Configuration



APPLICATIONS

- Tradesmen
- Commercial Cleaners
- Shipping & Logistics
- Hire & Rental



STANDOUT FEATURES



JW® Enhanced Italian triplex plunger pump running at 1450RPM delivers more performance and longer life.



Electric start Industrial V-Twin Honda™ GX630 Series Engine with digital engine hour meter.



Jetwave Safety System™ (JSS) thermal and safety valve to prevent overheating in excessive bypass and over pressurisation.



Optional: Seamless & sealed 40L on-board oversized water bypass tank with low level cut out, for enhanced industrial design, functionality and user experience.



Battery isolator.



Emergency stop.

STANDARD EQUIPMENT



J5000™ High Pressure Gun + Twin Lance with Nozzles.



15m Double Wire Braid Hose with M22 Couplings.

DIMENSIONS (MM)

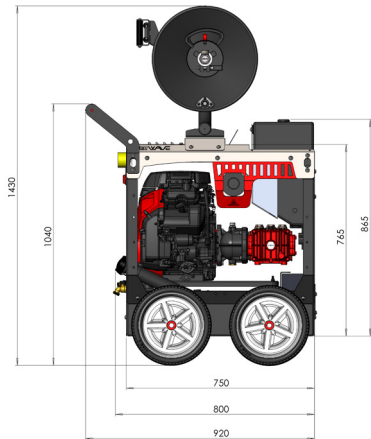
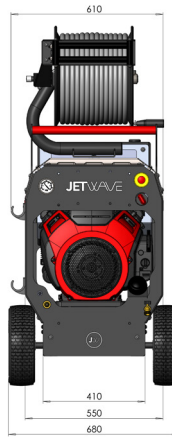

TECHNICAL DATA

SENATOR G2₂₇₅

SENATOR G2₃₀₀

Product Code	CW4000-20PEG2	CW4350-21PEG2
Pressure / Flow Rate	4000 PSI (275 BAR) / 20 L/PM	4350 PSI (300 BAR) / 21 L/PM
Max Water Inlet Temp	60C°	
Class (ASNZS: 4223)	A (5,500 Bar/Litres)	B (6,300 Bar/Litres)
Usage Frequency	Professional - 4 Hours Daily	
Nozzle Size	O5	O55
Frame Structure	CNC Modular galvanised steel chassis plus satin powder coat finish and stainless steel cover	

MOTOR FEATURES

Engine / Power	Honda™ GX630 Electric Key Start (air cooled) 20 HP / 630 CC
Fuel Type / Capacity / Protection	Unleaded / 25L (w/level gauge) / Low Oil Shutdown



HYDRAULIC FEATURES

Pump / Head / Pistons	JW® Italian Triplex Plunger / Brass (Nickle Plated) / Ceramic
Motor Pump Coupling / Pump RPM	Gearbox Drive / 1450RPM
Unloader Valve	Independent
Safety Valve	Yes
Detergent Injector	Yes - Downstream low pressure (power boost)

DIMENSIONS & WEIGHT

Machine Dimensions / Weight	Skid: 750mm(L) x 550mm(W) x 765mm(H) / 195KG
-----------------------------	--

WARRANTY(S)

Unit / Pump Warranty*	 2 Years
Engine Warranty*	 3 Years

OPTIONAL ACCESSORIES

30m Hose Reel	1060C MPL
60m Hose Reel	1067C MPL
Additional High Pressure Hose	52001
JW12 Foaming Lance w/1L Tank	JWA221-LS12
JW Bypass Pro Foam	PROFOAM
Turbo Head w/Lance (300BAR)	JWA160
21" Hammerhead - Plastic	JWA-FSC21
21" Hammerhead - Stainless Steel	JWA-FSC21-5

OPTIONAL UPGRADES

iGX700 EFI Engine Upgrade	ADD:FI
40L On-Board Water Tank w/low level cut out	90008-40ROTOC MPL
4 Wheel Trolley Kit	JWA407A
Front Double Stack Kit	JWA-429C
Top Double Stack Kit	JWA-430C
Low Pressure Inlet Hose Reel w/30m hose	1065C MPLLP
Hose Reel Roller Guide System HGS™	1067-GUIDEASSY (1067 Only)

The manufacturer reserves the right to modify design features and technical facts without notice, due to our principals of continuous improvement.

*Coverage against defects in material and workmanship (refer to Jetwave's and component partners T&Cs).

V2.2 08/21